



# PTZ100

## COMPACT PTZ CAMERA SYSTEM

The PTZ100 is a small color camera with pan-and-tilt and lights generally used for overviewing applications. It has 10x optical and 32x digital zoom.

### APPLICATIONS

- The PTZ100 is an overview camera system
- The CCU100 is needed to control the system
- The PTZ100 is not compatible with Ahlberg Cameras standard CCUs and cables

### BENEFITS

- Extensive zoom
- Auto-focus and auto-iris

### SPECIFICATIONS

Width	123 mm (4.85")
Height	277 mm (10.9")
Weight	4.4 kg (9.7 lbs)
Housing material	Stainless steel EN 1.4301/EN 1.4436, AISI 304/AISI 316
Radiation tolerance (dose rate)	50 Gy/h (5 000 rad/h)
Radiation tolerance (total dose)	300 Gy (30 000 rad)
Maximum temperature	50°C (short-term up to 70°C) 122°F (short-term up to 158°F)
Water tightness	min 3.5 bar (50 psi)
Zoom	x10 optical zoom, x32 digital zoom
SD horizontal angle of view	~5°-54°
Resolution SD version	700 TV-lines
Lights	2 Ahl-Light 1, in total 1800 lumen
Pan angle	±180°
Tilt angle	±90° (from the vertical plane)

*We reserve the right to alter specifications without prior notice*

**PTZ100 IMAGES**

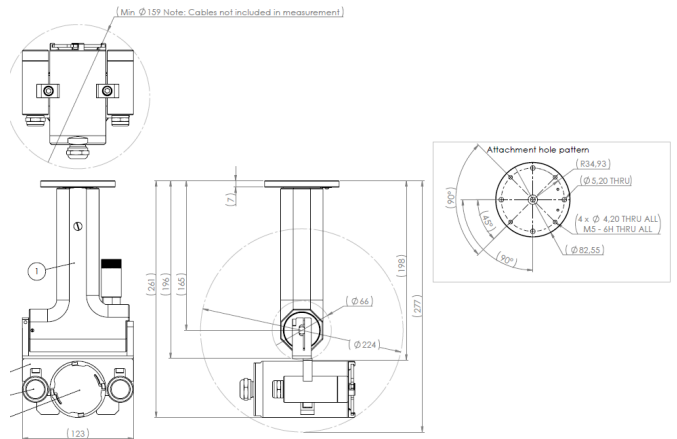

*We reserve the right to alter specifications without prior notice*